

de - Abluftanschluss versetzen. Der Umbau erfolgt vor der Montage.
 en - Repositioning the ducting. Repositioning is carried out before installing the cooker hood.
 fr - Déplacement du raccordement d'évacuation. Il faut procéder aux modifications avant le montage.
 it - Modificare la condotta evacuazione aria. Effettuare la modifica prima dell'installazione.
 es - Cambiar la conexión de salida de aire. El cambio se realiza antes del montaje.
 nl - Luchtafvoeraansluiting verplaatsen. De ombouw moet vóór de montage gebeuren.
 da - Udluftningstilslutning flyttes. Ombygningen skal foretages før monteringen.
 fi - Poistoilmaliitännän siirtäminen. Puhaltimen asento täytyy vaihtaa ennen liitäntöjen asentamista.

ru - Перестановка воздуховода. Переналадка проводится перед монтажом.
 el - Μετατόπιση σύνδεσης εξαγωγής αέρα. Η μετατροπή γίνεται πριν από την τοποθέτηση.
 pt - Mudar o canhão de saída de ar. A alteração é efectuada antes da montagem.
 tr - Hava Tahliye Bağlantısının Değiştirilmesi. Bu değişim montajdan önce yapılır.
 sv - Flytta frånluftsanslutningen. Ommonteringen görs innan själva grundmonteringen.
 no - Flytting av utluftningstilkoblingen. Ombyggingen må gjøres før monteringen.
 pl - Przekładanie przyłącza wylotowego. Przebudowa odbywa się przed montażem.

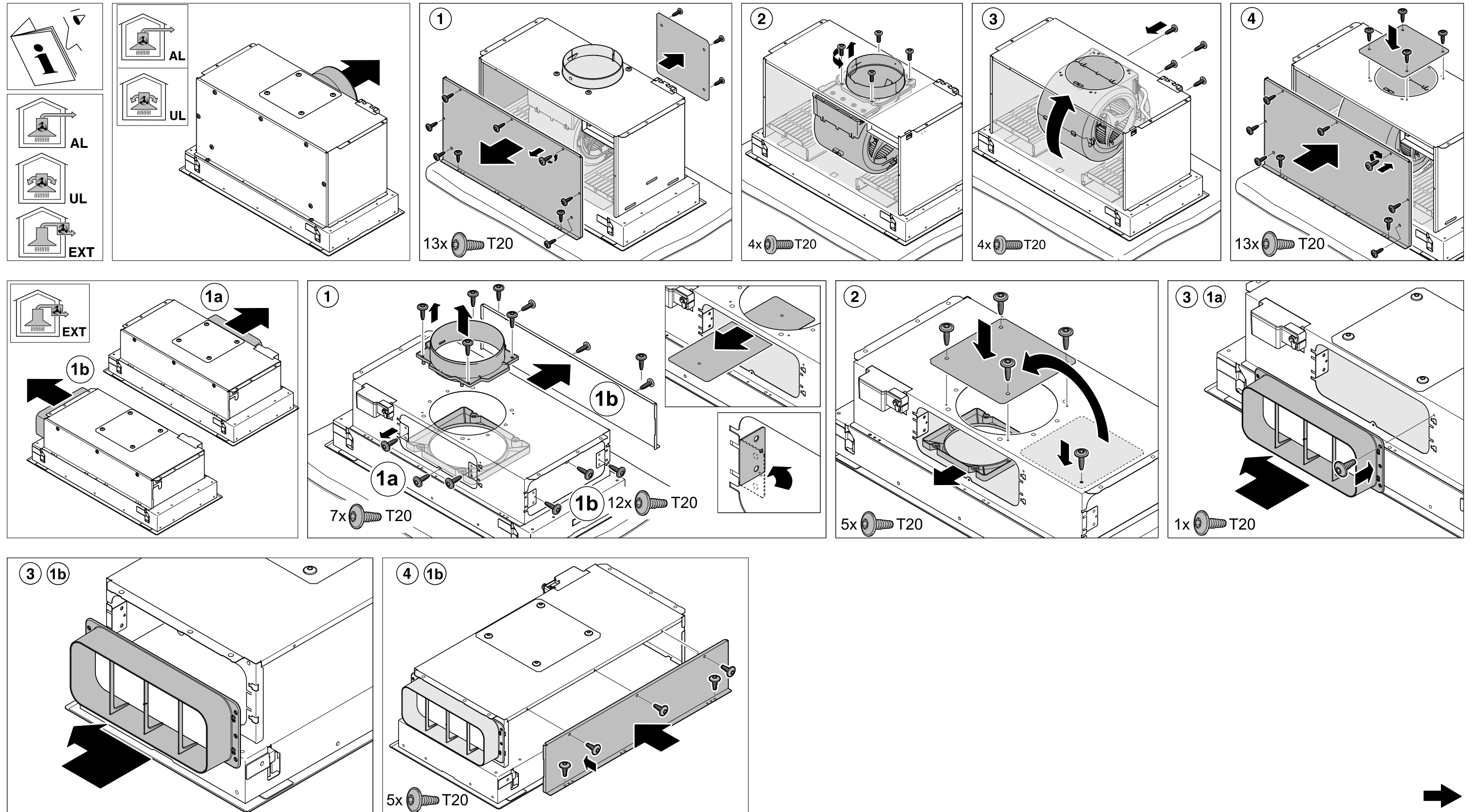

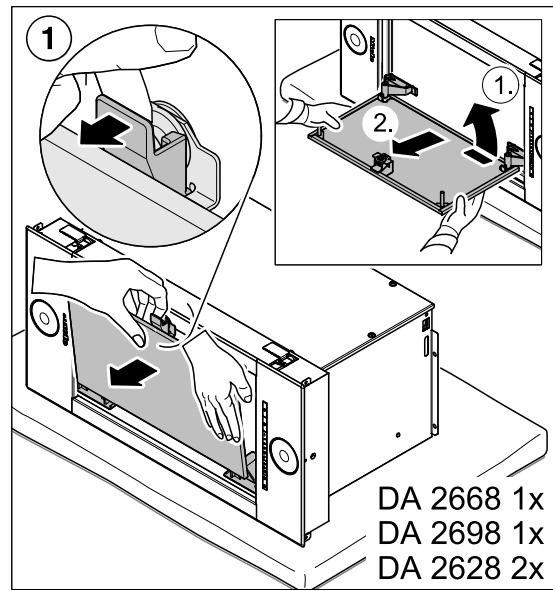

DA 2668 1x
DA 2698 1x
DA 2628 2x

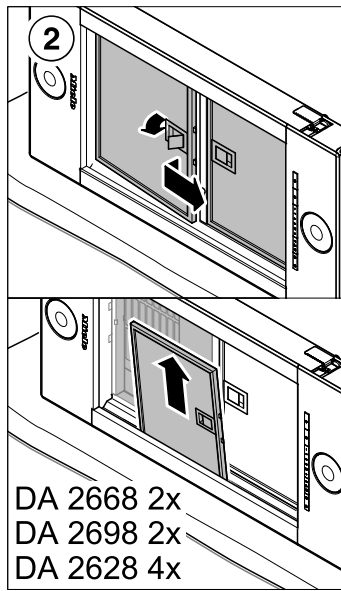

DA 2668 2x
DA 2698 2x
DA 2628 4x

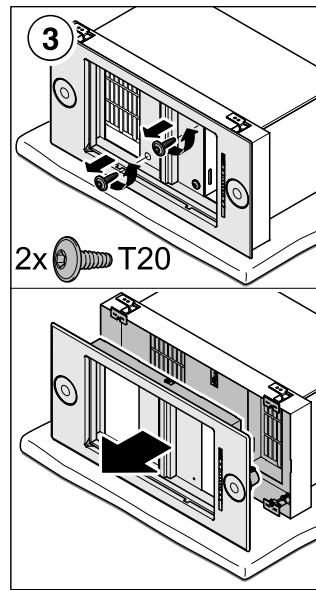

2x T20

